

FLANGE MOUNT JACK

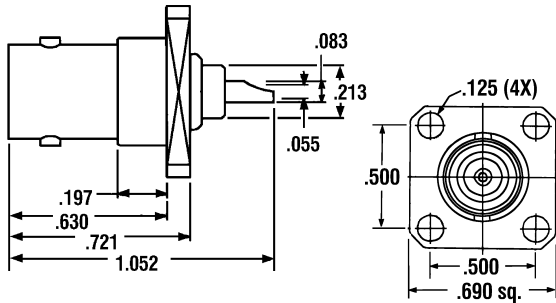

RECEPTACLE

MODEL	2215A-*
NOTES	captured center contact extended teflon solder pot terminal

FLANGE MOUNT JACK

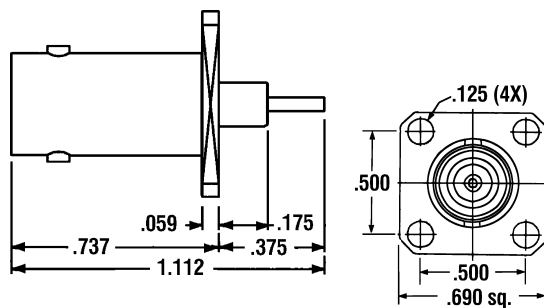

RECEPTACLE

MODEL	2204-CC-*
NOTES	captured center contact blunt post

FRONT MOUNT BULKHEAD JACK

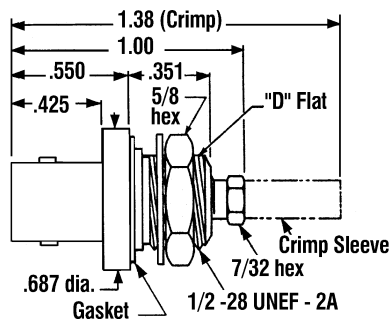

FOR FLEXIBLE, SEMI-RIGID OR ULTRA-FLEX CABLE

MODEL	2578-5XX-*	2578-7XX-*	2578-4XX-*
CABLE GROUP	23, 24, 26, 29	23, 24, 26, 29	30, 31
NOTES	clamp type for flexible cable	crimp type for flexible cable	solder-clamp for semi-rigid and Ultra-Flex cable

REAR MOUNT BULKHEAD JACK

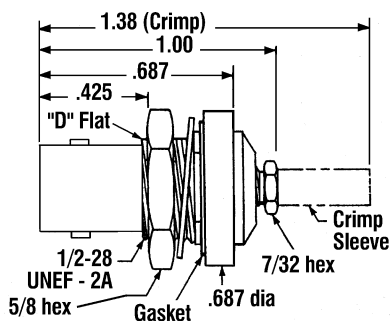

FOR FLEXIBLE, SEMI-RIGID OR ULTRA-FLEX CABLE

MODEL	2540-5XX-*	2540-7XX-*	2540-4XX-*
CABLE GROUP	23, 24, 26, 29	23, 24, 26, 29	30, 31
NOTES	clamp type for flexible cable	crimp type for flexible cable	solder-clamp for semi-rigid and Ultra-Flex cable

*-1 indicates gold plating, -4 indicates silver plating, -7 indicates nickel plating.